

City of Othello

Public Works Department • 111 North Broadway Avenue • Othello, WA 99344 • (509) 488-6997

Backflow Device Permit Application



All home and/or business owners installing a backflow prevention device are required to have a City of Othello Backflow Device Permit on file with the City of Othello Public Works Department. A Backflow Device Permit will be issued upon successful completion of inspection by the City of Othello Public Works Department. A certified backflow tester must test the device upon completion of installation, and yearly thereafter to ensure proper operation. Backflow test results must be submitted annually to the City of Othello Public Works Department at the address listed below.

OWNER INFORMATION *Please complete the owner/device information portion of this form and return to the address listed below*

CONTACT NAME (PROPERTY OWNER, COMPANY, ETC.): _____

ORGANIZATION NAME (IF APPLICABLE): _____

ADDRESS OF DEVICE: _____

CITY: _____ STATE: _____ ZIP: _____

PHONE: _____ FAX: _____

OWNER SIGNATURE: _____ DATE: _____

DEVICE INFORMATION *Please indicate the type of backflow prevention device that will be installed by selecting the corresponding box below. See pages 3-4 for information on backflow device options.*

1. **AIR GAP/ATMOSPHERIC VACUUM BREAKER**
Used for high health hazard situations and considered the maximum protection available against back-pressure backflow or back-siphonage. Not always practical and can be vulnerable to bypass arrangements.

3. **DOUBLE CHECK VALVE ASSEMBLY (DCVA)**
Most commonly used/desirable for testing purposes. Used to isolate non-health hazards. Installed above or below ground and effective against backpressure backflow and back-siphonage. Requires annual testing by State-certified tester.

2. **PRESSURE VACUUM BREAKER ASSEMBLY (PVBA)**
Used to isolate health or non-health hazards but is effective against back-siphonage only. Must be installed 12" above highest piping point. Requires annual testing by State-certified tester.

4. **REDUCED PRESSURE BACKFLOW ASSEMBLY (RPBA)**
Used to protect against backpressure backflow and back-siphonage. Installed above ground and used for high-hazard situations. Requires annual testing by State-certified tester.

Please submit form to:
City of Othello Public Works Department
111 North Broadway Avenue
Othello, WA 99344
P: (509) 488-6997 F: (509) 488-3701

FOR OFFICE USE ONLY

(TO BE COMPLETED BY CITY OF OTHELLO PUBLIC WORKS DEPARTMENT)

TYPE OF DEVICE: Reduced Pressure Backflow Assembly (RPBA) SERIAL NO.: _____
 Double Check Valve Assembly (DCVA) MODEL NO.: _____
 Pressure Vacuum Breaker Assembly (PVBA) BRAND OF DEVICE: _____
 Air Gap/Atmospheric Vacuum Breaker SIZE: _____

PRESSURE RATING: _____ TEMP.: _____ DATE INSPECTED: _____

INSPECTION PASSED INSPECTION FAILED

INSPECTOR NAME: _____ INSPECTOR SIGNATURE: _____

COMMENTS: _____



THE NEED FOR BACKFLOW PREVENTION DEVICES

Every year hundreds of people become ill as a result of consuming contaminated drinking water in their own homes. From drain cleaner entering the water system through the sink and exiting through shower water, to pesticides siphoned from a garden hose and filled into a drinking glass; contamination of the potable water supply can happen in a number of ways. Water supply contamination can be prevented and it is up to the home and business owners to ensure the proper steps are taken to do so.

Over the years, water treatment processes have become more complex in an effort to provide the highest quality water possible to the water utilities customers. The protection of the water sources, rivers, wells, and lakes, combined with new water treatment procedures, enable the water purveyor to achieve this goal.

A cross connection, as defined by the Cross Connection Control Committee of the Pacific Northwest (PNW) Section or the American Water Works Association (AWWA), is "Any actual or potential physical connection between a potable water line and any pipe, vessel, or machine containing a non-potable fluid or has the possibility of containing a non-potable fluid, solid or gas, such that it is possible for the non-potable fluid, solid or gas to enter the potable water system by backflow."

From the Federal Safe Water Drinking Act, the Washington State Department of Health Drinking Water Regulations requires the purveyor of water to develop and implement a cross connection control program using the manual published by the PNW Section - AWWA. The scope and complexity of the program is directly related to the size of the system.

CITY OF OTHELLO CROSS-CONNECTION CONTROL REQUIREMENTS

The City of Othello requires that all new water system installation locations' protect the City of Othello's drinking water supply with the use a backflow prevention device. The owner of the backflow prevention device must apply for a City of Othello Backflow Device Permit (page 5) with the City of Othello Public Works Department. The water customer is required to ensure that these devices are operated, maintained, and tested in accordance with the City of Othello's Cross Connection Control Regulations.

The correct backflow preventer must be installed properly, in the correct location, per the manufacturer specifications in order to comply with OMC 12.22 and the specifications of the City of Othello Backflow Device Permit Application. Per OMC 12.22, all home/business owners' installing a backflow prevention device are required to have the device inspected and approved by the City of Othello Public Works prior to use. A certified backflow tester will then need to test the device upon completion of installation, and yearly thereafter to ensure proper operation. A list of certified backflow testers can be found on page 4 of this packet. For more information on the different types of backflow devices, please see pages 2-3 of this guide.



THE FOUR TYPES OF BACKFLOW PREVENTION ASSEMBLIES

Below is an overview of the four types of backflow prevention assemblies. Please select an assembly that most fits your needs, as each assembly has different features and purposes.

Pressure Vacuum Breaker Assembly (PVBA)

A PVB is a mechanical backflow preventer that consists of an independently acting, spring-loaded check valve and an independently acting, spring-loaded air inlet valve on the discharge side of the check valve. It includes shutoff valves at each end of the assembly and is equipped with test cocks. A PVB may be used to isolate health or non-health hazards but is effective against backsiphonage only.

- Used for irrigation systems supplied by City water only
- Installed 12" above highest piping point
- State requires annual testing by State-certified tester

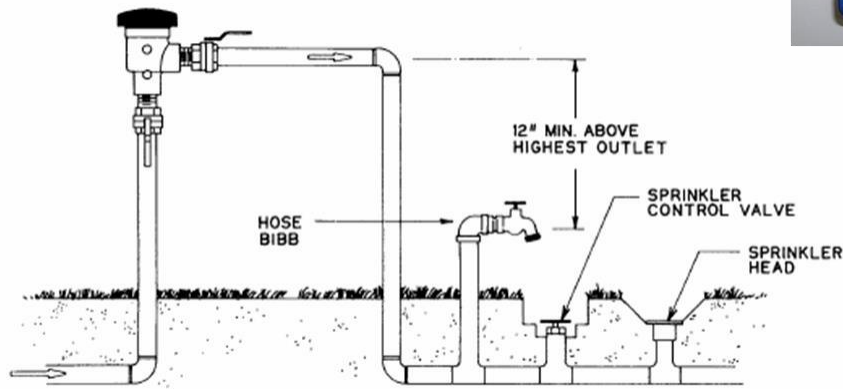

Double Check Valve Assembly (DCVA)

A DCVA is a mechanical backflow preventer that consists of two independently acting, spring-loaded check valves. It includes shutoff valves at each end of the assembly and is equipped with test cocks. A DCVA is effective against backpressure backflow and backsiphonage but should be used to isolate only non-health hazards.

- Highly versatile
- Install anywhere (above or below ground)
- Used for irrigation systems supplied by City water only
- Low-hazard sites such as apartment buildings
- State requires annual testing by State-certified tester

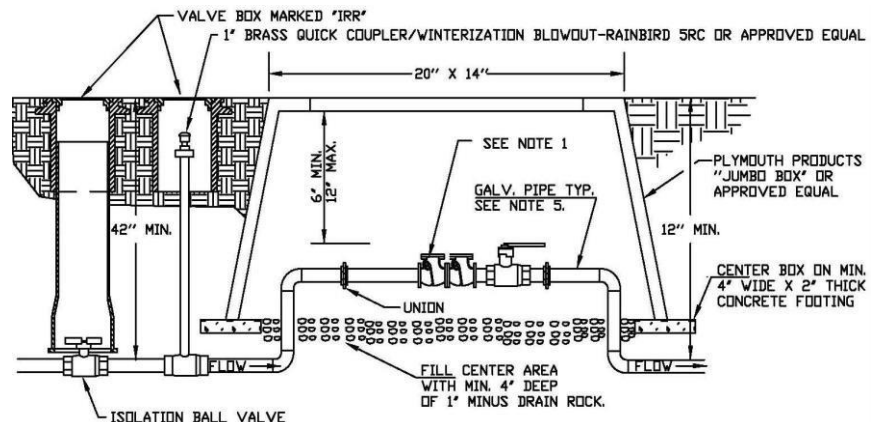



Reduced Pressure Backflow Assembly (RPBA)

An RPBA is a mechanical backflow preventer that consists of two independently acting, spring-loaded check valves with a hydraulically operating, mechanically independent, spring-loaded pressure differential relief valve between the check valves and below the first check valve. It includes shutoff valves at each end of the assembly and is equipped with test cocks. An RPBA is effective against backpressure backflow and backsiphonage and may be used to isolate health or non-health hazards.



- Usually most expensive and complex
- Installed above ground
- Used at high-hazard sites such as hospitals, chemical plants, mortuaries
- Only device that allows for applying fertilizer or other chemicals into irrigation systems
- State requires annual testing by State-certified tester

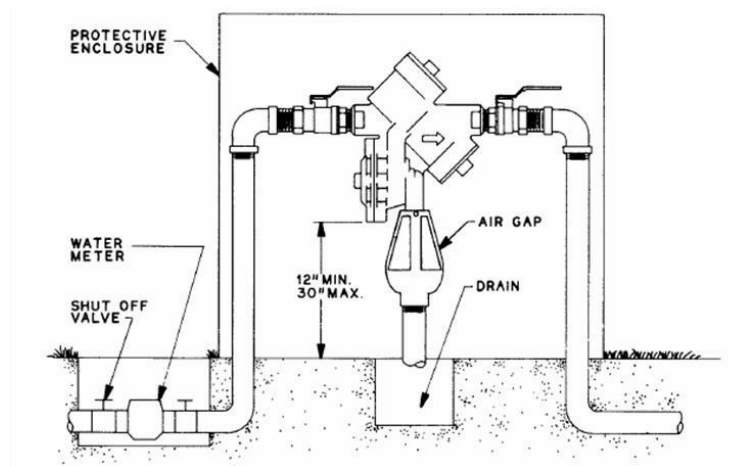

Air Gap

An air gap is a vertical, physical separation between the end of a water supply outlet and the flood-level rim of a receiving vessel. This separation must be at least twice the diameter of the water supply outlet and never less than one inch. An air gap is considered the maximum protection available against backpressure backflow or backsiphonage, but is not always practical and can easily be bypassed.

- Used for high health hazard situations
- Not always practical
- Vulnerable to bypass arrangements
- Use of an air gap often exposes water to dust, debris, airborne bacteria, and other contaminants and pollutants

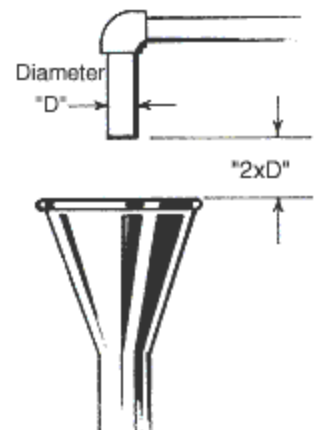



BACKFLOW ASSEMBLY TESTERS PRE-APPROVED FOR SUBMITTING TEST REPORTS TO THE CITY OF OTHELLO AND ADAMS COUNTY

The following table lists Backflow Assembly Testers (BATs) that are pre-approved to test backflow assemblies in our water system’s service area. We compiled the list by identifying individual testers who requested to work in this area or who previously submitted properly completed test reports to our system. *Note: listing does not constitute an endorsement of these BATs by our system or a certification of the quality of services they provide.*

To appear on our pre-approved BAT list, the tester must:

- Show proof of current BAT certification from DOH;
- Submit documentation that his/her assembly test equipment has been verified for accuracy within the last 12 months and calibrated if needed; and
- Meet other criteria established by our system including current City of Othello business license.

As an alternative to the above, pre-approved testers must document that they appear on the approved BAT list of another nearby water system that has a testing QA/QC program acceptable to our system.

WAC 246-290-490 requires a DOH-certified BAT to test all assemblies (RPBA, RPDA, DCVA, etc.) that protect the distribution system. Assemblies that protect the public water system must be tested in accordance with DOH-approved field test procedures:

- Upon installation, and annually thereafter;
- After repair, reinstallation, or relocation; and
- After a backflow incident.

Note: the DOH BAT certification is a special certification separate from other waterworks operator certification categories, plumbing licenses, contractor registration, etc. Other licenses, certifications and/or registrations may be required to install backflow prevention assemblies and/or perform maintenance work on assemblies within buildings. However, only a currently DOH-certified BAT may test the assemblies that protect the public water system from contamination.

City of Othello

Jim’s Backflow Testing	McKinstry Co.	Backflows Northwest	Pacific Fire Inspect Services
Jim Laird 699 Sara Ln Othello, WA 99344 (509) 660-0481	850 Spokane Falls Blvd Spokane, WA 99202 (509) 625-3128 (509) 747-3389	Jeremy Simkins 223F Cameron Lake Loop Rd Okanogan, WA 98840 (425) 277-2888	Tim Makeeff 725 S. Tacoma Ave. Kennewick, WA 99336 (509) 948-3971
Rell’s Fire Protection	Byam Plumbing, LLC.	D&B Backflow	Inland Fire Protection
7574 Pettigrew Lane Moses Lake, WA 98837 (509) 765-3353 800-950-3164	Chris Byam Plumber/BAT Moses Lake, WA (509) 765-1256	Richard Shubert PO Box 3602 Wenatchee, WA 98801 (509) 670-9867	3028 GS Center Rd. Wenatchee, WA 98801 (509) 884-6717 (509) 667-1705 (fax)

Adams County

Name	Contact Number	BAT Certificate #
Laird, Jim	(509) 660-0481	B6761